



This manual is for reference and historical purposes, all rights reserved.

This page is copyright© by M. Butkus, NJ.

This page may not be sold or distributed without the expressed permission of the producer

I have no connection with any camera company

On-line camera manual library

This is the full text and images from the manual. This may take 3 full minutes for the PDF file to download.

If you find this manual useful, how about a donation of \$3 to: M. Butkus, 29 Lake Ave., High Bridge, NJ 08829-1701 and send your e-mail address so I can thank you. Most other places would charge you \$7.50 for a electronic copy or \$18.00 for a hard to read Xerox copy.

This will allow me to continue to buy new manuals and pay their shipping costs.

It'll make you feel better, won't it?

**If you use Pay Pal or wish to use your credit card,
click on the secure site on my main page.**

OLYMPUS

OLYMPUS
Pen

D



OLYMPUS OPTICAL CO., LTD.

A large, bold, white letter 'D' is set against a black square background in the top-left corner of the page.

PEN-D

Congratulations on purchasing your Olympus Pen-D. You have chosen the most advanced model of the famous Pen series.

The compactness of the Pen-D and its advanced features make it eminently suitable for the most discerning amateur.

Carry your Pen-D with you always for constant enjoyment of photography.

D

SPECIFICATIONS

- Lens :** Six element F Zuiko lens
F 1.9 $f=32\text{mm}$
- Shutter :** Copal X, B, 8, 15, 30, 60, 125, 250, 500, X synchronization.
- Finder :** Bright Frame with parallax correction marks.
- Film Winding :** One motion thumb wind at camera rear.
- Rewind :** Fold down crank type rewind lever.
- Focusing :** Meter . . . 0.8m to infinity, click stops at 1.2m and 3m.
Feet 2.6 feet to infinity, click stops at 4' and 10'.
- Exposure Meter :** Built-in exposure meter
scaled EV numbers from 7 to 17.
- Available Film :** ASA 10 to 400.
- Dimensions :** 108 × 67 × 50 mm
- Weight :** 400 gr.

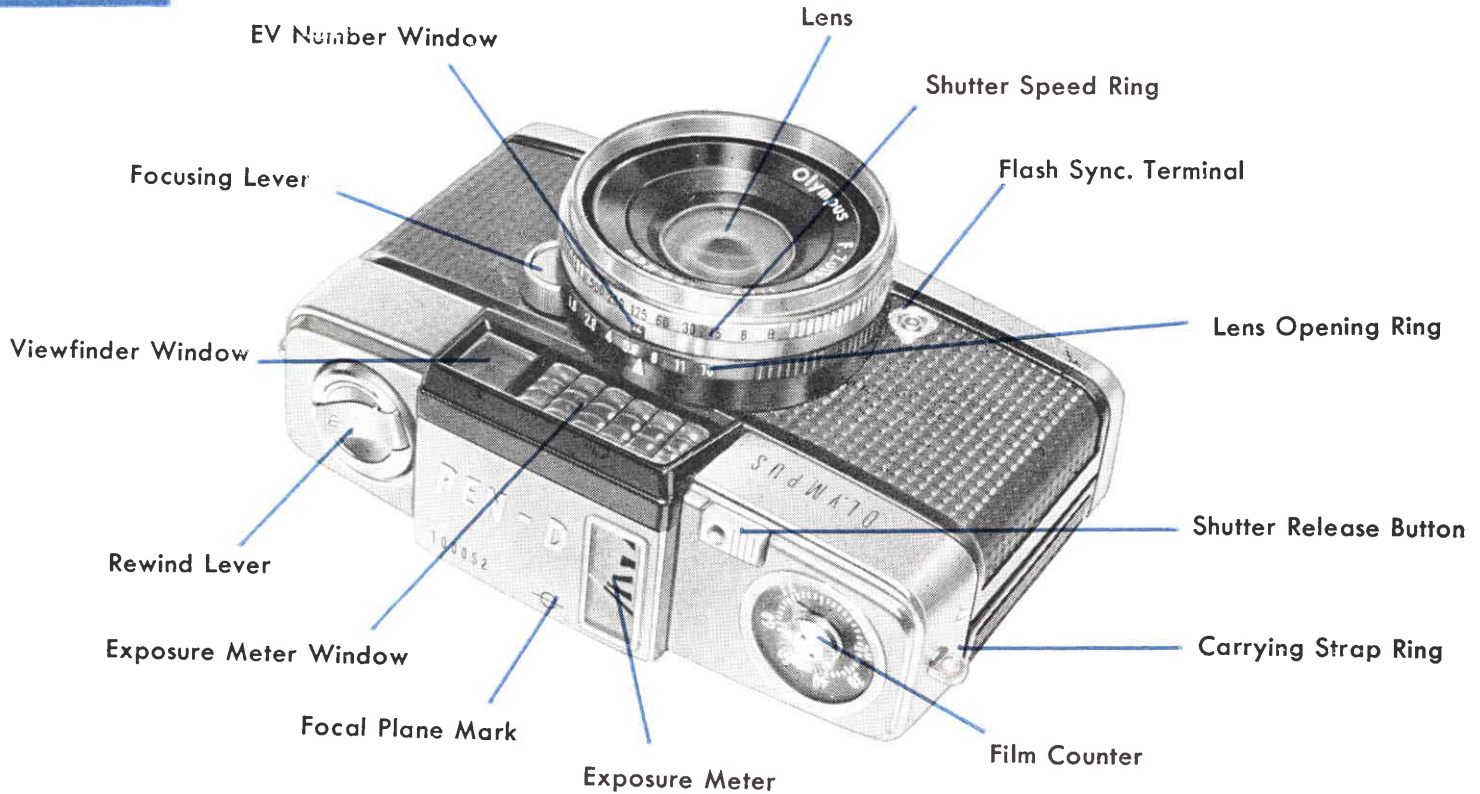

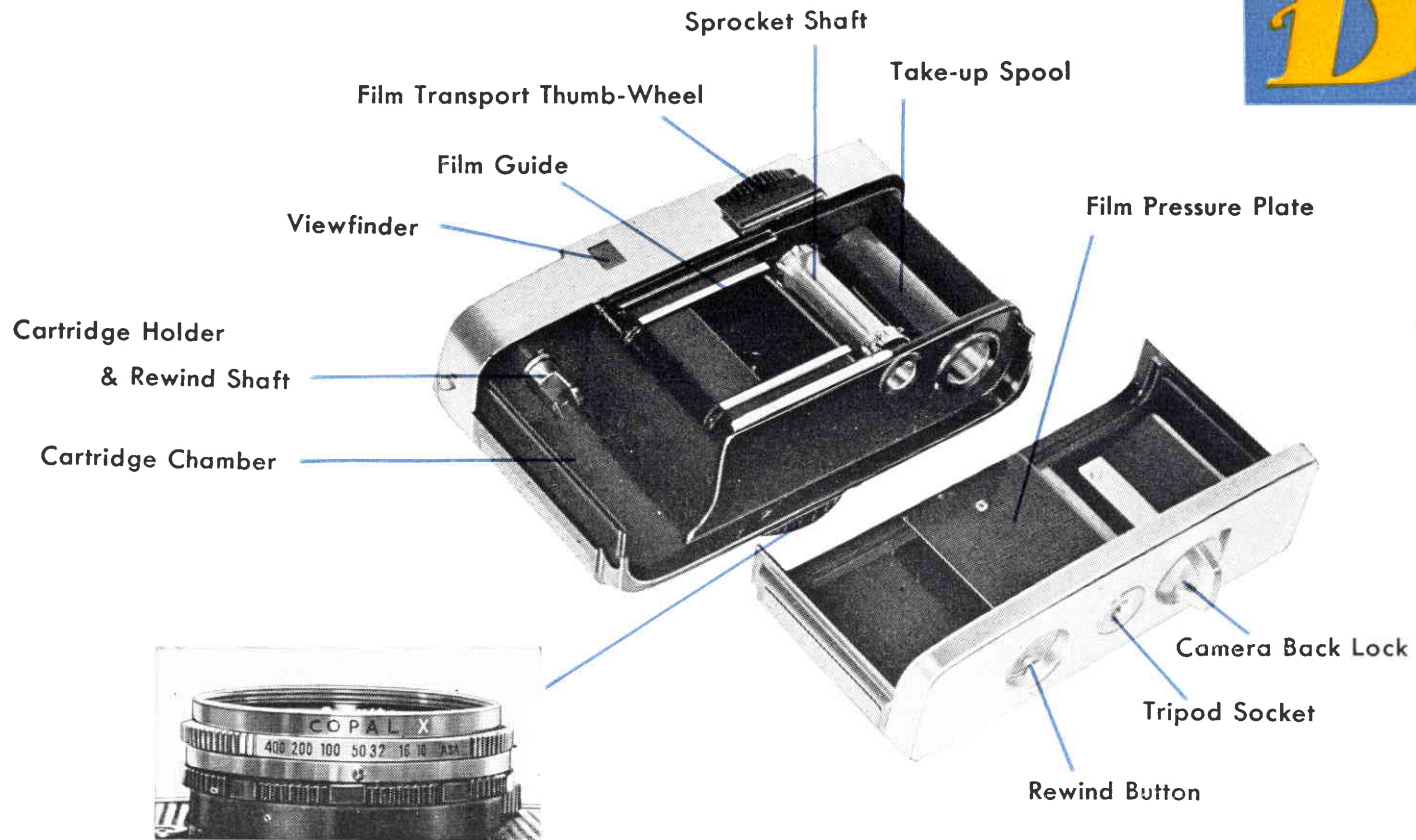



F-ZUIKO F 1.9 f=32MM LENS

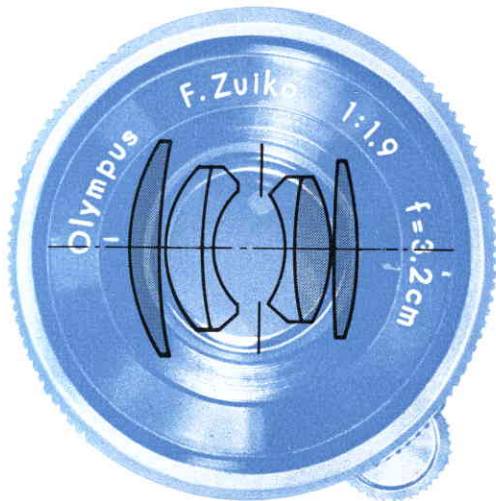

The Olympus Pen-D is equipped with an F 1.9 lens which is generally considered to be the fastest that can be fitted to lens-shutter cameras.

The superb 6 element lens is made from a new rare-earth glass and has been developed by Olympus technicians with over 40 years experience in lens design.

A fast 1/500 sec. shutter is fitted and the use of extremely thin blades minimizes shutter shock.

These and all the other features of the Pen-D will ensure that you will get needle-sharp pictures.

The $f=32\text{mm}$ lens is equivalent to a 45mm lens on a full 35mm frame.



FILM SIZE

The Pen-D accepts any regular 35mm film, color or black and white, all ASA speeds. No special film is necessary. The Pen-D takes the identical films that any 35mm camera takes.

On a regular 20 exposure roll, the Pen-D gives you 40 exposures. The picture size is 18mm \times 24mm (about $\frac{3}{4}$ " \times 1"), exactly $\frac{1}{2}$ size of pictures taken with a regular 35mm camera. The film is processed in the same way, through the same places that other 35mm film is processed.

Pen Size

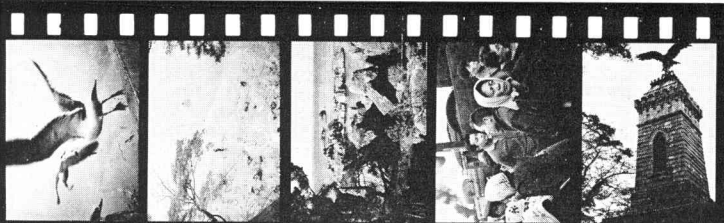

Regular 35mm Size

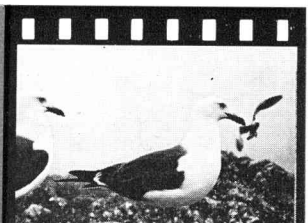



FILM LOADING

- 1) Flip up the lock at the camera base. Turn it in the direction of the arrow shown below. Then grasp the camera body with the left hand, the camera back with the right hand, and gently slide the camera back DOWN in the direction of the arrow shown in center photo below.
- 2) Slip the end of the new film into the Winding Spool.
- 3) Place the film cartridge in the cartridge chamber, being sure that the cartridge holder fits snugly within the top of cartridge. Be sure the sprockets on the sprocket holder engage the perforations in the film. Move the film slightly if necessary, or

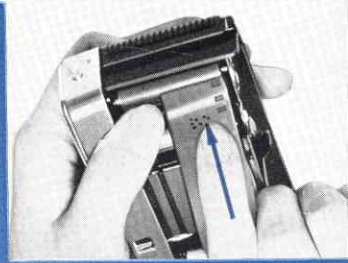

turn the rewind lever slightly to take up film slack. Replace the camera back and lock it securely. Wind the film once and release the shutter button. During this 1st wind, the film is being engaged in the sprocket spool, and the rewind lever will move in the same direction the film is moving. This is normal, and shows proper loading. Wind and expose the film three more times. Whenever you wind the film, be sure you wind it all the way. Never wind it half way or part way, but all the way.

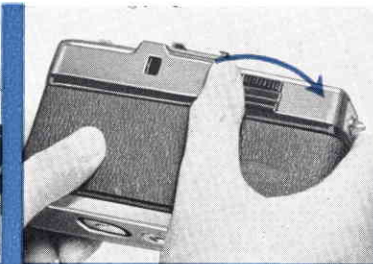
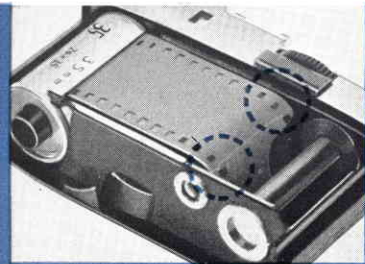



FILM COUNTER SELF-COCKING SHUTTER

After the 3 trial shots ; set the film counter. Place your thumb on the knurled round indicator, and turn until the triangle points to either 72 or 40. If you are using a 36 exposure roll, set the triangle to point to 72. If you are using a 20 exposure roll, set the triangle to point to 40. From that point on, the COUNTER SHOWS YOU HOW MANY PICTURES YOU CAN STILL TAKE BEFORE THE FILM IS ALL USED UP. If the pointer points to 27, for example, that means you can still take 27 more pictures on that roll of film.

When the film is completely wound for next picture, two operations take place automatically. The film is moved to the next frame and the shutter is cocked, ready for release. You need only press the release button to make an exposure.

The film Winding Roller should be rolled all the way until it stops. If not, the shutter will not operate. Do not wind the film immediately after you have taken a picture. Wait until you are ready for the next picture, and wind the film just before making the exposure. This enables the shutter springs to last and remain accurate indefinitely.



TO REWIND THE FILM AFTER THE LAST EXPOSURE

Flip up the rewind lever. Press down and HOLD the rewind button at the base of the camera body. SLOWLY turn the rewind crank in the direction of the arrow. You will feel a tension, which shows that the film is being rewound into the cartridge. At the rate of about 1 complete turn per second, turn the rewind crank until you feel the tension suddenly disappear. Then turn the rewind crank a few more times, and the film can be removed from the camera. If you turn the rewind crank too quickly in the Pen-D or in any camera ; the friction of the film against the pressure plate will cause tiny bits of dust to settle on the film.

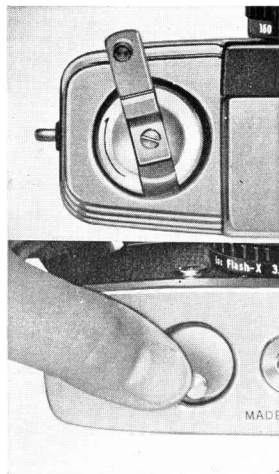

D

EXPOSURE METER

The built-in exposure meter is scaled by simple EV numbers from 7 to 17. Film speed in use should be set at the ASA number marked on the lower side of lens barrel. After reading the EV number by the exposure meter, set the EV number in the small window on the shutter speed ring. You will be able to get a correct exposure.

EV numbers decide the combination of the shutter speed, the lens opening and the film speed in use.

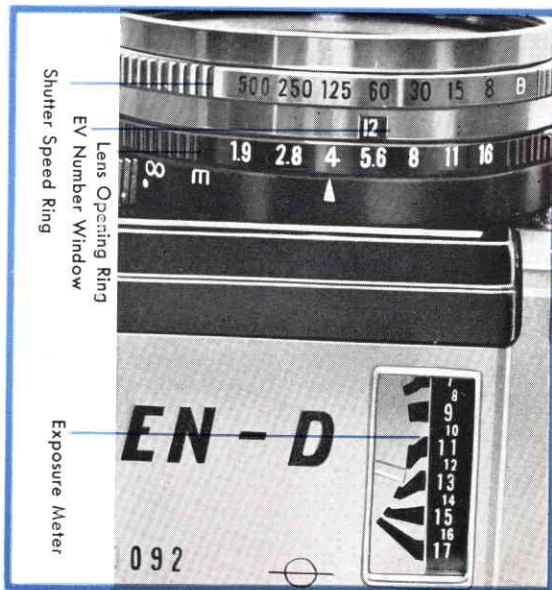

- 1) Read the EV number shown by the red needle of the exposure meter which is directed to the subject.
- 2) Set the number in the window, turning shutter speed ring or lens opening ring.
- 3) It is possible to select shutter speed or lens opening after the EV number has been set in the window. Hold shutter speed ring and lens opening ring together and rotate so as to obtain the shutter speed or lens opening selected.
- 4) This exposure meters covers a range of light conditions from F 1.9. 1/30 sec. to F 16. 1/500 sec.

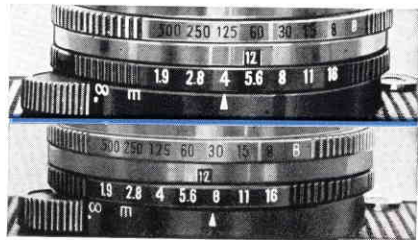



FOCUSING

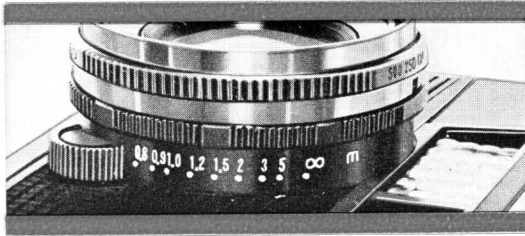

Estimate the distance from camera to subject, and set it by focusing lever. Make sure to set the distance at the upper edge of focusing lever.

The click stop at 4 feet (1.2m) is a convenient fixed focus for close-up, and the click stop at 10 feet is for snapshot.

The mark \oplus indicates the film position when loaded in camera. This is very useful to measure accurate distance.



TO USE THE VIEWFINDER

The Olympus Pen-D embodies an Extra Bright Luminous Frame Finder. Perfect composition is easy. Simply place the subject in the center of the frame. The Pen-D Finder is so constructed that regardless of the position of your eye, the subject will be centered.

When making close-ups (1 meter or closer), frame the subject in the yellow area. This automatically corrects for parallax.





TO MAKE A PERFECT PICTURE



- 1) Hold the camera firmly against your face.
- 2) Spread your feet apart so you will not sway back and forth, or side to side.
- 3) Be sure your fingers do not cover the lens, the viewfinder, or the framefinder. Be sure your fingers do not move the shutter ring after it is set.
- 4) Hold your breath as you press the shutter release button.
- 5) Use a lens shade when shooting into the sunlight.
- 6) Use a UV filter to shut out ultraviolet rays. (The filter can be used between pictures to protect the lens also).



Olympus Optical Company, manufacturer of not only Cameras, but also high quality Microscopes, Optical Measuring Instruments and Medical Instruments, is known as the best Manufacturer of all-round precision optical instruments in Orient.

This is a picture of Wakasagi (pond smelt)-Fishing in midwinter at Lake Suwa in Nagano Prefecture, famous place as Suisse of Orient where Olympus' Main Factory is located.



FLASH SYNCHRONIZATION



Selection of the shutter speed.

- 1) To use the Strobe light :
Electronic flash is synchronized at all speeds.
- 2) To use the Type F Bulb :
Set the shutter speed at 1/8 to 1/60.
- 3) To use the Type M Bulb :
Set the shutter speed at 1/8 to 1/30.

Selection of the lens opening.

Divide the guide number by distance and this is the lens opening figure.

EXAMPLE: Film Speed : ASA 100
Guide Number : 105
Distance to subject : 15 feet
 $105 \div 15 = 7$
Set the lens opening at 8 close to 7.

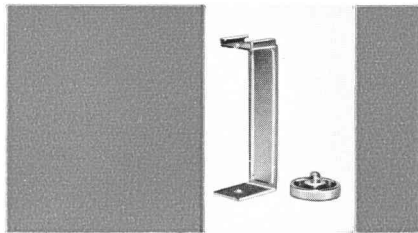

Filter : Haze (UV)
Skylight 1A
Conversion type A
Yellow (Y2)
43mm Screw-in type

Lens Shade : 45mm Slip-on type

When an yellow filter is attached, the ASA setting should be adjusted one f/stop lower. In other words see ASA at 50 instead of 100.

UV or Skylight filter is recommended for color pictures. ASA setting adjustment is not necessary for using these filters.

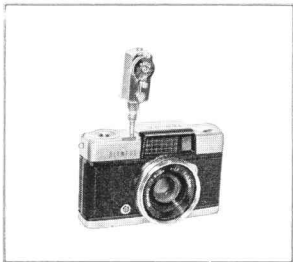
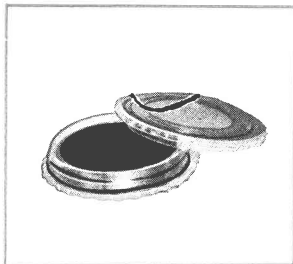

SELFTIMER

As illustrated you can use an attachable self-timer which is available in any camera store.



DEPTH OF FOCUS

Our eyes can look at a newspaper, or a person across the table, or a three miles away, and they will all be sharp to us. If something very close and very far is sharp to us at the same time—like our eyes see things—it is called great "depth of focus".

In the case of a camera lens the depth of focus is decided by the focal length of lens and lens opening. F Zuiko F 1.9 $f=32\text{mm}$ (equivalent to a 45mm lens on a full 35mm frame) gives greater depth of focus than regular 50mm lens.

As you can see in the next page, the depth of focus increases as you use a higher f/stop .

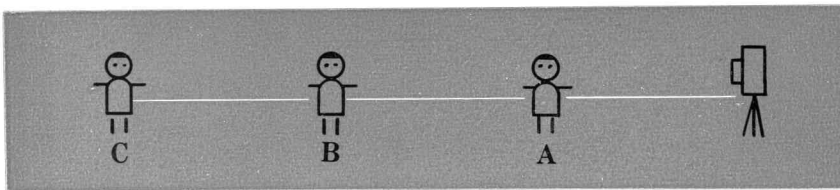

OLYMPUS PEN-D DEPTH OF FOCUS

(Meter Scale)

Diaphragm Lens Stop. Focussing	1.9	2.8	4	5.6	8	11	16
∞	13.47 ∞	9.14 ∞	6.40 ∞	4.57 ∞	3.20 ∞	2.32 ∞	1.60 ∞
5	3.67 7.85	3.26 10.79	2.85 21.64	2.43 ∞	2.00 ∞	1.64 ∞	1.27 ∞
3	2.47 3.38	2.28 4.38	2.07 5.48	1.85 8.26	1.59 ∞	1.36 ∞	1.10 ∞
2	1.75 2.32	1.66 2.51	1.55 2.83	1.42 3.42	1.27 4.96	1.12 11.56	0.94 9.16
1.5	1.36 1.67	1.30 1.76	1.23 1.91	1.15 2.15	1.05 2.66	0.95 3.80	0.82 14.00
1.2	1.11 1.30	1.07 1.36	1.02 1.44	0.97 1.57	0.90 1.82	0.82 2.28	0.72 3.97
1	0.93 1.06	0.91 1.10	0.88 1.15	0.84 1.24	0.78 1.38	0.73 1.62	0.65 2.31
0.9	0.85 0.95	0.83 0.98	0.80 1.02	0.72 1.19	0.68 1.36	0.68 1.36	0.61 1.81
0.8	0.76 0.84	0.74 0.86	0.72 0.89	0.69 0.94	0.66 1.01	0.62 1.13	0.56 1.42



(Feet Scale)

Lens Focussing	Diaphragm Stop.	1.9	2.8	4	5.6	8	11	16
∞		41.07 ∞	27.87 ∞	19.51 ∞	13.93 ∞	9.75 ∞	7.07 ∞	4.88 ∞
15		11.23 22.43	10.10 29.39	8.87 ∞	7.64 ∞	6.34 ∞	5.23 ∞	4.07 ∞
10		8.22 12.79	7.58 14.75	6.88 18.57	6.12 28.48	5.26 ∞	4.49 ∞	3.61 ∞
7		6.09 8.23	5.74 8.99	5.33 10.25	4.87 12.64	4.32 19.50	3.79 ∞	3.16 ∞
5		4.53 5.58	4.33 5.91	4.10 6.42	3.83 7.25	3.49 9.04	3.14 13.12	2.70 ∞
4		3.69 4.35	3.57 4.55	3.41 4.83	3.23 5.28	2.99 6.15	2.73 7.76	2.40 13.95
3.5		3.27 3.76	3.17 3.90	3.05 4.11	2.90 4.42	2.71 5.01	2.50 6.00	2.22 9.07
3		2.83 3.18	2.76 3.28	2.67 3.42	2.56 3.64	2.41 4.01	2.25 4.61	2.02 6.19
2.6		2.47 2.73	2.42 2.80	2.35 2.90	2.27 3.05	2.15 3.30	2.02 3.69	1.85 4.61

